

# Rosemount 2090F Hygienic Pressure Transmitter



- Conforms to 3-A<sup>®</sup> Sanitary Standards
- Features CIP/SIP service for process temperatures up to 284 ° F (140 ° C)
- Absolute or gage pressure ranges up to 300 psi
- Mounts with either 1 1/2- or 2-in. Tri-Clamp<sup>®</sup> connection
- Utilizes Rosemount solid-state, polysilicon sensor for industry leading reliability and performance

# Accurate, stable, and reliable pressure measurement for the Hygienic Industries

## Conforms to 3-A Sanitary Standards

The hygienic design of the 2090F conforms to 3-A Sanitary Standards, and is USDA accepted. The materials of construction are Generally Recognized As Safe (GRAS) by the FDA, making it the ideal choice for any hygienic application.

## Features CIP/SIP service with an upper temperature limit of 284 °F (140 °C)

The 2090F provides accurate, stable, and reliable pressure measurement, which makes it an ideal choice for pharmaceutical and food and beverage applications, including CIP/SIP service for process temperatures up to 284 °F (140 °C).

## Absolute or gauge pressure ranges up to 300 psi and 20:1 turndown

Higher turndown allows for lower inventories by allowing you to measure pressures from 1.5 psi to 300 psi with only three transmitter ranges.

## Mounts with either 1 1/2-in or 2-in. Tri-Clamp connection

The 2090F is available with both 1 1/2-in. and 2-in. Tri-Clamp process connections, designed for sanitary applications to easily connect to standard sanitary fittings without requiring special mounting hardware.

## Utilizes single-filled sensor system for reliability and outstanding accuracy

The 2090F sensor has a single-filled system with Neobee M-20 fill fluid which is approved as an indirect food additive according to the FDA. Its benefits include reliability, low oil fill for less temperature effect, and outstanding accuracy due to full sensor compensation.

---

## Contents

Ordering Information .....	3	Product Certifications .....	8
Specifications .....	6	Dimensional Drawings .....	12

## Ordering Information

Specification and selection of product materials, options, or components must be made by the purchaser of the equipment. See [page 7](#) for more information on Material Selection.

- ★ The Standard offering represents the most common options. The starred options (★) should be selected for best delivery. The Expanded offering is manufactured after receipt of order and is subject to additional delivery lead time.

Model	Product description			
2090F	Hygienic Pressure Transmitter			
<b>Transmitter type</b>				
A	Absolute			★
G	Gage			★
<b>Pressure ranges (range/min. span)</b>				
	<b>2090FG</b>	<b>2090FA</b>		
1	-14.7 to 30 psi / 1.5 psi (-1,01 to 2,1 bar / 103 mbar)	0 to 30 psia / 1.5 psi (0 to 2,1 bar / 103 mbar)		★
2	-14.7 to 150 psi / 7.5 psi (-1,01 to 10,3 bar / 517 mbar)	0 to 150 psia / 7.5 psi (0 to 10,3 bar / 517 mbar)		★
3	-14.7 to 300 psi / 40 psi (-1.01 to 20,7 bar / 2,8 bar)	0 to 300 psia / 40 psi (0 to 20,7 bar / 2,8 bar)		★
<b>Output</b>				
S	4–20 mA dc/Digital HART Protocol			★
<b>Material of construction</b>				
	Process Connection	Isolating Diaphragm	Oil Fill	
2D	316L SST	316L SST	Neobee	★
<b>Code</b>	<b>Process connection</b>			
E	1 <sup>1</sup> / <sub>2</sub> -in. Tri-Clamp Connection			★
F	2-in. Tri-Clamp Connection			★
<b>Conduit entry</b>				
1	1/2–14 NPT			★
2	M20 × 1.5 female			★

### Options (include with selected model number)

<b>Extended product warranty</b>				
WR3	3-year limited warranty			★
WR5	5-year limited warranty			★
<b>Digital display</b>				
M5	LCD display, configured for percent of range			★
M7	LCD display, configured for engineering units			★
<b>Mounting brackets</b>				
B4	SST mounting bracket with SST Bolts			★

- ★ The Standard offering represents the most common options. The starred options (★) should be selected for best delivery.  
The Expanded offering is manufactured after receipt of order and is subject to additional delivery lead time.

<b>Product certifications</b>		
E5	FM Explosion-Proof, Dust Ignition-proof	★
ED	ATEX Flameproof	★
EM	Technical Regulations Customs Union (EAC) Flameproof	★
I5	FM Intrinsically Safe, Nonincendive	★
K5	FM Explosion-Proof, Dust Ignition-proof, Intrinsically Safe, Division 2	★
I1	ATEX Intrinsic Safety	★
N1	ATEX Type n	★
C6	CSA Explosion-Proof, Intrinsically Safe, and Non-incendive	★
KB	FM and CSA Explosion-Proof, Dust Ignition-proof, Intrinsically Safe, Division 2	★
KM	Technical Regulation Customs Union (EAC) Flameproof and Intrinsic Safety	★
KH	FM Approvals and ATEX Explosion-Proof and Intrinsically Safe	★
ND	ATEX Dust	★
NK	IECEx Dust	★
K7	SAA Flameproof, Dust Ignition-proof, Intrinsic Safety, Type n	★
K1	ATEX Flameproof, Intrinsic Safety, Type n, Dust	★
K6	CSA and ATEX Explosion-proof and Intrinsically Safe Approvals	★
I3	China Intrinsic Safety	★
IM	Technical Regulation Customs Union (EAC) Intrinsic Safety	★
E3	China Flameproof	★
<b>Terminal blocks</b>		
T1	Transient Protection	★
<b>Special certificate</b>		
Q4	Calibration Certificate	★
<b>Alarm limit</b>		
C4	NAMUR alarm and saturation levels, high alarm	★
CN	NAMUR alarm and saturation levels, low alarm	★
<b>Special procedures</b>		
P2	Cleaning for Special Service	
<b>Calibration accuracy</b>		
P8	0.1% Accuracy to 10:1 Turndown	★
<b>Typical model number: 2090FG 2 S 2D E 1</b>		

## Standard configuration

Unless otherwise specified, transmitter is shipped as follows:

- Engineering units: psi
- 4 mA: 0 psi
- 20 mA: Upper Range Limit
- Alarm Output High
- LCD Display: 0–100%

## Custom configuration

### Calibration

Transmitters are factory calibrated to customer's specified range. If calibration is not specified, transmitters are calibrated at maximum range. Calibration is at ambient temperature and pressure.

### Tagging

The transmitter will be tagged, at no charge, in accordance with customer requirements. All tags are stainless steel. The standard tag is wired to the transmitter. Tag character height is  $\frac{1}{8}$  in. (0.318 cm). A permanently attached tag is available upon request.

### Accessories

Item description	Part number
Calibration Adapter, 1½ inch Use to connect a calibration device to a transmitter.	02088-0197-0011
Calibration Adapter, 2 inch Use to connect a calibration device to a transmitter.	02088-0197-0012

# Specifications

## Functional specifications

### Service

Liquid, gas, vapor, and high-viscosity applications

### Ranges

Range	Minimum span	Upper (URL)	Lower (LRL)	Lower <sup>(1)</sup> (LRL) (gage)
1	1.5 psi (103 mbar)	30 psi (2,1 bar)	0 psia (0 bar)	-14.7 psig (-1,01 bar)
2	7.5 psi (517 mbar)	150 psi (10,3 bar)	0 psia (0 bar)	-14.7 psig (-1,01 bar)
3	40 psi (2,76 bar)	300 psi (20,7 bar)	0 psia (0 bar)	-14.7 psig (-1,01 bar)

(1) Assumes atmospheric pressure of 14.7 psig.

### Output

4–20 mA dc/Digital HART Protocol

### Rangedown

20:1

### Load limitations

Maximum loop resistance is determined by the power supply voltage, as described by the following equation:

$$\text{Max. Loop Resistance} = 43.5 (\text{Power Supply Voltage} - 10.5)$$

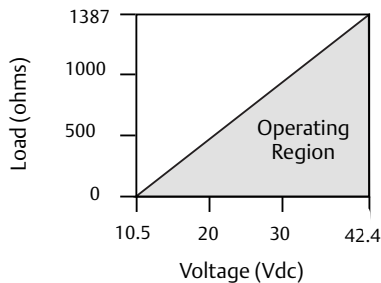

The Field Communicator requires a minimum loop resistance of 250Ω for communication.

### Power supply

External power supply required. Transmitter operates on 10.5–36 V dc with no load. Reverse polarity protection is standard.

### Zero elevation and suppression

Zero can be suppressed between atmosphere (2090FG), or 0 psia (2090FA) and upper range limit, if the calibrated span is equal to or greater than the minimum span, and the upper range value does not exceed the upper range limit.

### Overpressure limits

Range 1: 120 psig max  
All other ranges: Twice the upper range limit

### Temperature limits

#### Process

–4 to 284 °F (–20 to 140 °C)

#### Ambient

–4 to 185 °F (–20 to 85 °C)

#### Storage

–22 to 185 °F (–30 to 85 °C)

Process temperatures above 185 °F (85 °C) require lowering the ambient limits by a 1.5:1 ratio:

$$\text{Max. Ambient temperature in } ^\circ\text{F} = 185 - \frac{(\text{Process Temp} - 185)}{1.5}$$

$$\text{Max. Ambient temperature in } ^\circ\text{C} = 85 - \frac{(\text{Process Temp} - 85)}{1.5}$$

### Humidity limits

0–100% relative humidity

### Volumetric displacement

Less than 0.00042 cm<sup>3</sup>

### Turn-on time

2.0 seconds, no warm-up required

### Failure alarm

If self-diagnostics detect a sensor or microprocessor failure, the analog signal is driven either high or low to alert the user. High or low failure mode is user-selectable by a jumper on the transmitter. The values to which the transmitter drives its output in failure mode depend on whether it is factory-configured to *standard* or *NAMUR-compliant* operation. The values for each are as follows:

#### Standard operation

Linear Output: 3.9 ≤ I ≤ 20.8  
Fail High: I ≥ 21.75 mA  
Low: I ≤ 3.75 mA

#### NAMUR-compliant operation

Linear Output: 3.8 ≤ I ≤ 20.5  
Fail High: I ≥ 22.5 mA  
Low: I ≤ 3.6 mA

## Transmitter security

Activating the transmitter security function prevents changes to the transmitter configuration, including local zero and span adjustments. Security is activated by an internal jumper.

## Performance specifications

(Zero-based spans, reference conditions, and 316 SST isolating diaphragm.)

### Reference accuracy

±0.20% of calibrated span. Includes combined effects of linearity, hysteresis, and repeatability.

### Ambient temperature effect per 100 °F (56 °C)

±(0.3% URL + 0.3% of span) from -40 to 185 °F (-40 to 85°C)

### Stability

±0.10% of upper range limit for 12 months

### Time response

Less than 200 ms time constant (63.2% response to a step change in pressure)

### Vibration effect

Less than ±0.1% of upper range limit when subjected to vibration of peak to peak constant displacement of 4 mm (5–15 Hz) and constant acceleration of 2 g (15–150 Hz) and 1 g (150–2000 Hz).

### Power supply effect

Less than 0.01% of calibrated span per volt

### Mounting position effect

Zero shift of up to 1.2 inH<sub>2</sub>O (0,3 kPa), which can be calibrated out. No span effect

### RFI effect

Less than ±0.25% of upper range limit from 20–1000 MHz at 30 V/m with leads in conduit. Less than ±0.25% of upper range limit from 20-1000 MHz at 10 V/m with unshielded twisted pair (no conduit).

## Physical specifications

### Material selection

Emerson provides a variety of Rosemount product with various product options and configurations including materials of construction that can be expected to perform well in a wide range of applications. The Rosemount product information presented is intended as a guide for the purchaser to make an appropriate selection for the application. It is the purchaser's sole responsibility to make a careful analysis of all process parameters (such as all chemical components, temperature, pressure, flow rate, abrasives, contaminants, etc.), when specifying product, materials, options and components for the particular application. Emerson Process Management is not in a position to evaluate or guarantee the compatibility of the process fluid or other process parameters with the product, options, configuration or materials of construction selected.

### Electrical connection

1/2-14 NPT or M20 × 1.5 conduit entry

### Process wetted parts

#### Isolating diaphragm

316L stainless steel

#### Process connector

316L stainless steel

### Non-wetted parts

#### Electronics housing

Low-copper aluminum, NEMA 4X, IP65, IP67, CSA enclosure Type 4X

#### Paint

Polyurethane

#### Cover O-rings

Buna-N

#### Paint

Polyurethane

#### Cover O-rings

Buna-N

#### Fill fluid

Neobee<sup>®</sup> M-20

#### Weight

Approximately 2.74 lb (1.24 kg)

# Product Certifications

## European Directive Information

A copy of the EC Declaration of Conformity can be found at the end of the Quick Start Guide. The most recent revision of the EC Declaration of Conformity can be found at [www.rosemount.com](http://www.rosemount.com).

## Ordinary Location Certification from FM Approvals

As standard, the transmitter has been examined and tested to determine that the design meets the basic electrical, mechanical, and fire protection requirements by FM Approvals, a nationally recognized test laboratory (NRTL) as accredited by the Federal Occupational Safety and Health Administration (OSHA).

### North America

- E5** FM Explosionproof (XP) and Dust-Ignitionproof (DIP)  
Certificate: 1V2A8.AE  
Standards: FM Class 3600 – 1989, FM Class 3615 – 1989, FM Class 3810 – 1989  
Markings: XP CL I, DIV 1, GP B, C, D; DIP CL II, DIV 1, GP E, F, G; CL III; T5(-40 °C ≤ T<sub>a</sub> ≤ +85 °C); Factory Sealed; Type 4X
- I5** FM Intrinsic Safety (IS) and Nonincendive (NI)  
Certificate: 0V9A7.AX  
Standards: FM Class 3600 – 1998, FM Class 3610 – 2010, FM Class 3611 – 2004, FM Class 3810 – 1989  
Markings: IS CL I, DIV 1, GP A, B, C, D; CL II, DIV 1, GP E, F, G; Class III; DIV 1 when connected per Rosemount drawing 02088-1018; NI CL 1, DIV 2, GP A, B, C, D; T4(-40 °C ≤ T<sub>a</sub> ≤ +70 °C); Type 4x

#### Special Condition for Safe Use (X):

1. The Model 2088 transmitter with the transient terminal block (Option code T1) will not pass the 500Vrms dielectric strength test and this must be taken into account during installation

- C6** CSA Explosionproof, Dust-Ignitionproof, Intrinsic Safety and Nonincendive  
Certificate: 1015441  
Standards: ANSI/ISA 12.27.01-2003, CSA Std. C22.2 No. 30 -M1986, CSA Std. C22.2 No.142-M1987, CSA Std. C22.2. No.157-92, CSA Std. C22.2 No. 213 - M1987  
Markings: Explosionproof for Class I, Division 1, Groups B, C and D; Dust-Ignitionproof Class II, Division 1, Groups E, F, G; Class III Division 1; Intrinsically Safe Class I, Division 1 Groups A, B, C, D when connected in accordance with Rosemount drawing 02088-1024, Temperature Code T3C; Class I Division 2 Groups A, B, C and D; Type 4X; Factory Sealed; Single Seal

### Europe

- ED** ATEX Flameproof  
Certificate: KEMA97ATEX2378X  
Standards: EN60079-0:2006, EN60079-1:2007, EN60079-26:2007  
Markings: Ⓔ II 1/2 G Ex d IIC T6/T4, T6(-40 °C ≤ T<sub>a</sub> ≤ +40 °C), T4(-40 °C ≤ T<sub>a</sub> ≤ +80 °C)

#### Special Condition for Safe Use (X):

1. This device contains a thin wall diaphragm. Installation, maintenance and use shall take into account the environmental conditions to which the diaphragm will be subjected. The manufacturer’s instructions for installation and maintenance shall be followed in detail to assure safety during its expected lifetime. For information on the dimensions of the flameproof joints the manufacturer shall be contacted.

- I1** ATEX Intrinsic Safety  
Certificate: BAS00ATEX1166X  
Standards: EN60079-0:2012, EN60079-11:2012  
Markings: Ⓔ II 1 G Ex ia IIC T5/T4 Ga, T5(-55 °C ≤ T<sub>a</sub> ≤ +40 °C), T4(-55 °C ≤ T<sub>a</sub> ≤ +70 °C)

**Table 1. Input Parameters**

	HART
<b>Voltage U<sub>i</sub></b>	30 V
<b>Current I<sub>i</sub></b>	200 mA
<b>Power P<sub>i</sub></b>	0.9 W
<b>Capacitance C<sub>i</sub></b>	0.012 μF
<b>Inductance L<sub>i</sub></b>	0 mH

#### Special Condition for Safe Use (X):

1. The apparatus is not capable of withstanding the 500 V insulation test required by EN60079-11. This must be taken into account when installing the apparatus.

**N1** ATEX Type n  
 Certificate: BAS00ATEX3167X  
 Standards: EN60079-0:2012, EN60079-15:2010  
 Markings:  $\text{Ex II 3 G Ex nA IIC T5 Gc } (-40\text{ }^\circ\text{C} \leq T_a \leq +70\text{ }^\circ\text{C})$

**Special Condition for Safe Use (X):**

1. This apparatus is not capable of withstanding the 500 V insulation test that is required by EN60079-15. This must be taken into account when installing the apparatus.

**ND** ATEX Dust  
 Certificate: BAS01ATEX1427X  
 Standards: EN60079-0:2012, EN60079-31:2009  
 Markings:  $\text{Ex t IIC T50 } ^\circ\text{C T}_{500} 60\text{ }^\circ\text{C Da}$

**Special Conditions for Safe Use (X):**

1. The user must ensure that the maximum rated voltage and current (36 volts, 24 milliamps, d.c.) are not exceeded.
2. All connection to other apparatus or associated apparatus shall have control over this voltage and current to a category 'ib' circuit
3. Cable entries must be used which maintain the ingress protection of the enclosure to at least IP66
4. Unused cable entries must be filled with suitable blanking plugs which maintain the ingress protection of the enclosure to at least IP66
5. Cable entries and blanking plugs must be suitable for the ambient range of the apparatus and capable of withstanding a 7J impact test.
6. The 2088/2090 sensor module must be securely screwed in place to maintain the ingress protection of the enclosure.

**International**

**K7** IECEx Flameproof, Intrinsic Safety, Type n, and Dust  
 Certificate: IECEx KEM 06.0021X  
 Standards: IEC60079-0:2004, IEC60079-1:2003, IEC60079-26:2004,  
 Markings:  $\text{Ex d IIC T4...T6, T6 } (-20\text{ }^\circ\text{C} \leq T_a \leq +40\text{ }^\circ\text{C}), T4(-20\text{ }^\circ\text{C} \leq T_a \leq +80\text{ }^\circ\text{C});$

**Special Condition for Safe Use (X):**

1. This material of the diaphragm shall not be subjected to environmental conditions that might adversely affect the partition wall.

IECEx Intrinsic Safety  
 Certificate: IECEx BAS 12.0071X  
 Standards: IEC60079-0:2011, IEC60079-11:2011  
 Markings:  $\text{Ex ia IIC T5/T4 Ga, T5 } (-55\text{ }^\circ\text{C} \leq T_a \leq +40\text{ }^\circ\text{C}), T4(-55\text{ }^\circ\text{C} \leq T_a \leq +70\text{ }^\circ\text{C})$

**Table 2. Input Parameters**

	<b>HART</b>
<b>Voltage <math>U_i</math></b>	30 V
<b>Current <math>I_i</math></b>	200 mA
<b>Power <math>P_i</math></b>	0.9 W
<b>Capacitance <math>C_i</math></b>	0.012 $\mu\text{F}$
<b>Inductance <math>L_i</math></b>	0 mH

**Special Conditions for Safe Use (X):**

1. When fitted with a transient suppression terminal block, the Model 2088 is incapable of passing the 500 V isolation test. This must be taken into account during installation.
2. The enclosure may be made of aluminum alloy and given a protective polyurethane paint finish; however, care should be taken to protect it from impact or abrasion if located in a Zone 0 environment.

IECEx Type n  
 Certificate: IECEx BAS 12.0072X  
 Standards: IEC60079-0:2011, IEC60079-15:2010  
 Markings:  $\text{Ex nA IIC T5 Gc } (-40\text{ }^\circ\text{C} \leq T_a \leq +70\text{ }^\circ\text{C})$

**Special Condition for Safe Use (X):**

1. When fitted with a transient suppression terminal block, the Model 2088 is incapable of passing the 500 V isolation test. This must be taken into account during installation.

**NK** IECEx Dust  
 Certificate: IECEx BAS12.0073X  
 Standards: IEC60079-0:2011, IEC60079-31:2008  
 Markings:  $\text{Ex t IIC T50 } ^\circ\text{C T}_{500} 60\text{ }^\circ\text{C Da}$

**Special Conditions for Safe Use (X):**

1. Cable entries must be used which mention the ingress protection of the enclosure to at least IP66
2. Unused cable entries must be filled with suitable blanking plugs which maintain the ingress protection of the enclosure to at least IP66
3. Cable entries and blanking plugs must be suitable for the ambient range of the apparatus and capable of withstanding a 7J impact test.

**Technical Regulations Customs Union (EAC)**

**EM, IM, KM** Contact an Emerson Process Management representative for additional information

**Brazil**

- I2** INMETRO Intrinsic Safety  
 Certificate: UL-BR 13.0246X  
 Standards: ABNT NBR IEC60079-0:2008 + Errata 1:2011,  
 ABNT NBR IEC60079-11:2009  
 Markings: HART: Ex ia IIC T5/T4 Ga,  
 T5(-55 °C ≤ T<sub>a</sub> ≤ +40 °C), T4(-55 °C ≤ T<sub>a</sub> ≤ +70 °C)

**Table 3. Input Parameters**

	<b>HART</b>
<b>Voltage U<sub>i</sub></b>	30 V
<b>Current I<sub>i</sub></b>	200 mA
<b>Power P<sub>i</sub></b>	0.9 W
<b>Capacitance C<sub>i</sub></b>	0.012 μF
<b>Inductance L<sub>i</sub></b>	0 mH

**Special Conditions for Safe Use (X):**

1. When fitted with a transient suppression terminal block, the Model 2088 is incapable of passing the 500 V isolation test. This must be taken into account when installing the equipment.
2. The enclosure may be made of aluminum alloy and given a protective polyurethane paint finish; however, care should be taken to protect it from impact or abrasion if located in Zone 0.

**China**

- E3** China Flameproof  
 Certificate: GYJ111064  
 Standards: GB3836.1-2000, GB3836.2-2010  
 Markings: Ex d IIC T6/T4, T6(-20 °C ≤ T<sub>a</sub> ≤ +40 °C),  
 T4(-20 °C ≤ T<sub>a</sub> ≤ +80 °C)

**Special Conditions for Safe Use (X):**

1. The ambient temperature is as follows:

<b>T<sub>a</sub></b>	<b>Temperature class</b>
-20 °C ≤ T <sub>a</sub> ≤ 80 °C	T4
-20 °C ≤ T <sub>a</sub> ≤ 40 °C	T6

2. The earth connection facility in the enclosure should be connected reliably.
3. During installation in hazardous location, cable glands, conduits, and blanking plugs, certified by state-appointed inspection bodies with Ex d IIC type of protection, should be used.
4. Obey the warning “Do not open when energized.”
5. Installation and maintenance should be done in a non-hazardous environment
6. End user is not permitted to change any internal component

7. During installation, use and maintenance of this product, observe the following standards:  
 GB3836.13-1997 “Electrical apparatus for explosive gas atmospheres Part 13: Repair and overhaul for apparatus used in explosive gas atmospheres”  
 GB3836.15-2000 “Electrical apparatus for explosive gas atmospheres Part 15: Electrical installations in hazardous area (other than mines)”  
 GB3836.16-2006 “Electrical apparatus for explosive gas atmospheres Part 16: Inspection and maintenance of electrical installation (other than mines)”  
 GB50257-1996 “Code for construction and acceptance of electric device for explosion atmospheres and fire hazard electrical equipment installation engineering”.

- I3** China Intrinsic Safety  
 Certificate: GYJ111065X  
 Standards: GB3836.1-2000, GB3836.4-2000  
 Markings: Ex ia IIC T4/T5

**Special Conditions for Safe Use (X):**

1. This apparatus is not capable of withstanding the 500 V r.m.s. insulation test required by Clause 6.4.12 of GB3836.4-2000.
2. The ambient temperature is:

<b>T<sub>a</sub></b>	<b>Temperature class</b>
-55 °C ≤ T <sub>a</sub> ≤ 40 °C	T5
-55 °C ≤ T <sub>a</sub> ≤ 70 °C	T4

3. Intrinsically safe parameters:

	<b>HART</b>
<b>Voltage U<sub>i</sub></b>	30 V
<b>Current I<sub>i</sub></b>	200 mA
<b>Power P<sub>i</sub></b>	0.9 W
<b>Capacitance C<sub>i</sub></b>	0.012 μF
<b>Inductance L<sub>i</sub></b>	0 mH

4. The product should be used with Ex-certified linear associated apparatus to establish explosion protection system that can be used in explosive gas atmospheres. Wiring and terminals should comply with the instruction manual of the product and associated apparatus.
5. The cables between this product and associated apparatus should be shielded cables (the cables must have insulated shields). The shield has to be grounded reliably in a non-hazardous area.
6. End users are not permitted to change any internal components, but to settle the problem in conjunction with the manufacturer to avoid damage to the product.

- 7. During installation, use and maintenance of this product, observe the following standards:  
 GB3836.13-1997 “Electrical apparatus for explosive gas atmospheres Part 13: Repair and overhaul for apparatus used in explosive gas atmospheres”  
 GB3836.15-2000 “Electrical apparatus for explosive gas atmospheres Part 15: Electrical installations in hazardous area (other than mines)”  
 GB3836.16-2006 “Electrical apparatus for explosive gas atmospheres Part 16: Inspection and maintenance of electrical installation (other than mines)”  
 GB50257-1996 “Code for construction and acceptance of electric device for explosion atmospheres and fire hazard electrical equipment installation engineering”

**Combinations**

- K1** combination of ED, I1, ND and N1
- K5** combination of E5 and I5
- K6** combination of C6, ED and I1
- K7** combination of E7, I7, NK and N7
- K8** combination of K5 and C6
- KH** combination of ED, I1, K5

**Conduit Plugs and Adapters**

IECEx Flameproof and Increased Safety  
 Certificate: IECEx FMG 13.0032X  
 Standards: IEC60079-0:2011, IEC60079-1:2007,  
 IEC60079-7:2006-2007

Markings: Ex de IIC Gb

ATEX Flameproof and Increased Safety  
 Certificate: FM13ATEX0076X  
 Standards: EN60079-0:2012, EN60079-1:2007,  
 IEC60079-7:2007

Markings:  II 2 G Ex de IIC Gb

**Table 4. Conduit Plug Thread Sizes**

Thread	Identification Mark
M20 x 1.5	M20
½ - 14 NPT	½ NPT
G½A	G½

**Table 5. Thread Adapter Thread Sizes**

Male Thread	Identification Mark
M20 x 1.5 – 6H	M20
½ - 14 NPT	½ - 14 NPT
¾ - 14 NPT	¾ - 14 NPT
Female Thread	Identification Mark
M20 x 1.5 – 6H	M20
½ - 14 NPT	½ - 14 NPT
PG 13.5	PG 13.5

**Special Conditions for Safe Use (X):**

1. When the thread adapter or blanking plug is used with an enclosure in type of protection increased safety “e” the entry thread shall be suitably sealed in order to maintain the ingress protection rating (IP) of the enclosure.
2. The blanking plug shall not be used with an adapter.
3. Blanking Plug and Threaded Adapter shall be either NPT or Metric thread forms. G½ and PG 13.5 thread forms are only acceptable for existing (legacy) equipment installations.

# Dimensional Drawings

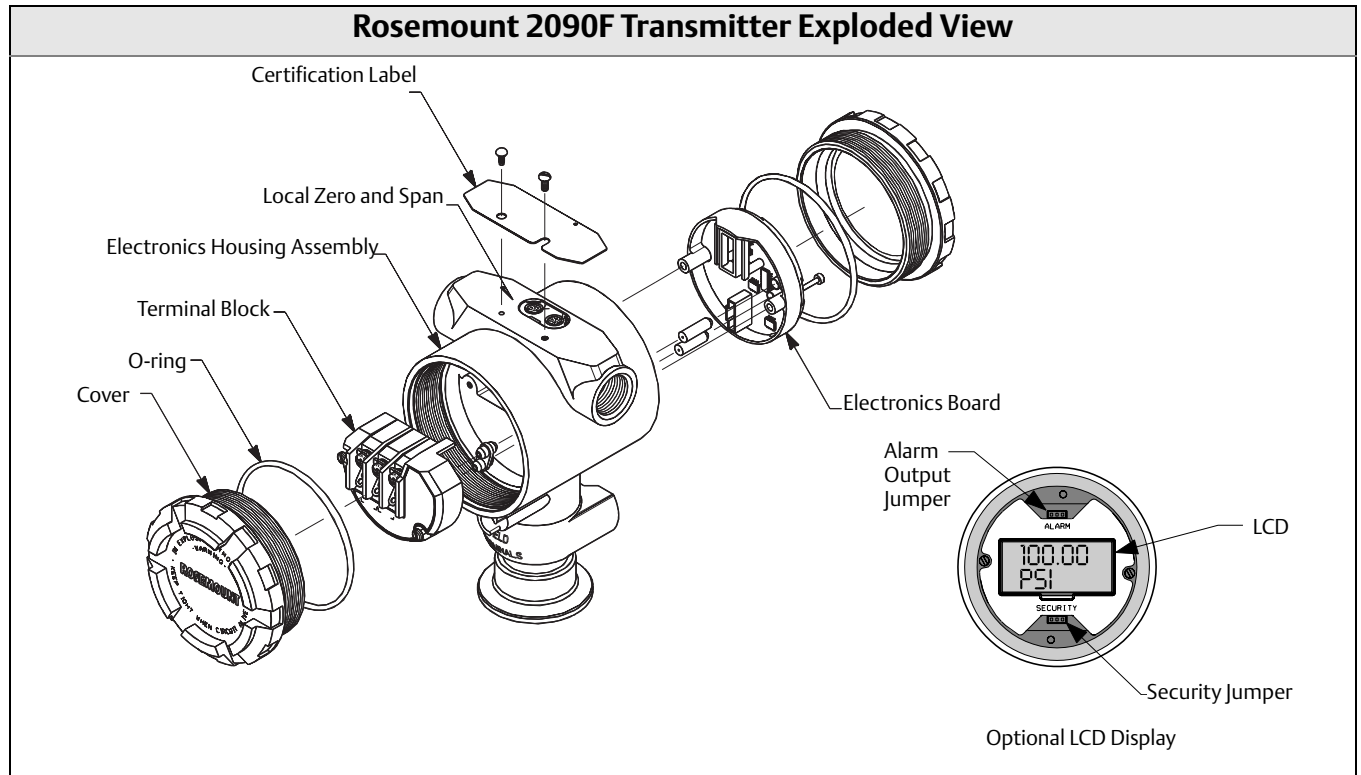
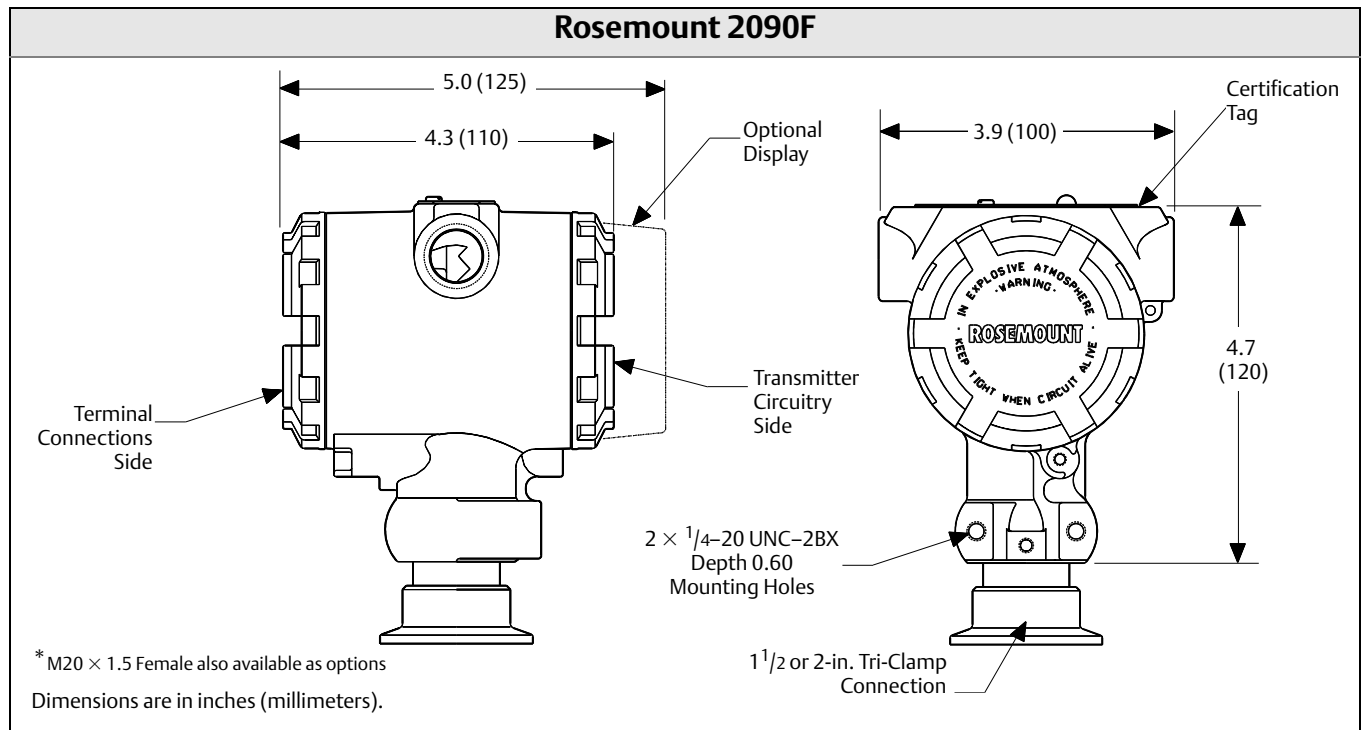



**Emerson Process Management  
Rosemount Measurement**  
8200 Market Boulevard  
Chanhassen, MN 55317 USA  
T (U.S.) 1-800-999-9307  
T (International) (952) 906-8888  
F (952) 906-8889  
[www.rosemount.com](http://www.rosemount.com)

**Emerson Process Management**  
Blegistrasse 23  
P.O. Box 1046  
CH 6341 Baar  
Switzerland  
T +41 (0) 41 768 6111  
F +41 (0) 41 768 6300  
[www.rosemount.com](http://www.rosemount.com)

**Emerson Process Management**  
Asia Pacific Pte Ltd  
1 Pandan Crescent  
Singapore 128461  
T +65 6777 8211  
F +65 6777 0947  
Service Support Hotline: +65 6770 8711  
Email: [Enquiries@AP.EmersonProcess.com](mailto:Enquiries@AP.EmersonProcess.com)  
[www.rosemount.com](http://www.rosemount.com)

**Emerson Process Management  
Latin America**  
1300 Concord Terrace, Suite 400  
Sunrise Florida 33323 USA  
T + 1 954 846 5030  
[www.rosemount.com](http://www.rosemount.com)

Standard Terms and Conditions of Sale can be found at [www.rosemount.com/terms\\_of\\_sale](http://www.rosemount.com/terms_of_sale)  
The Emerson logo is a trade mark and service mark of Emerson Electric Co.  
Rosemount and the Rosemount logotype are registered trademarks of Rosemount Inc.  
PlantWeb is a registered trademark of one of the Emerson Process Management group of companies.  
HART and WirelessHART are registered trademarks of the HART Communication Foundation  
Modbus is a trademark of Modicon, Inc.  
All other marks are the property of their respective owners.  
© 2014 Rosemount Inc. All rights reserved.